

TRANSISTOR (PNP)

FEATURES

Complimentary to SS8050W

MARKING: Y2

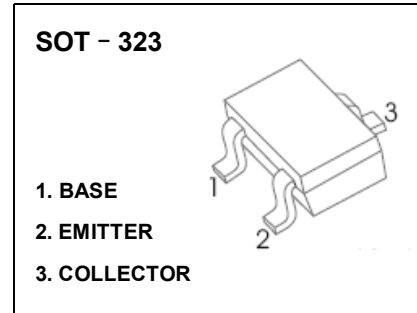

MAXIMUM RATINGS ($T_A=25^\circ\text{C}$ unless otherwise noted)

Symbol	Parameter	Value	Units
V_{CBO}	Collector-Base Voltage	-40	V
V_{CEO}	Collector-Emitter Voltage	-25	V
V_{EBO}	Emitter-Base Voltage	-5	V
I_C	Collector Current -Continuous	-1.5	A
P_C	Collector Power Dissipation	0.2	W
T_j	Junction Temperature	150	$^\circ\text{C}$
T_{stg}	Storage Temperature	-55-150	$^\circ\text{C}$

ELECTRICAL CHARACTERISTICS ($T_{amb}=25^\circ\text{C}$ unless otherwise specified)

Parameter	Symbol	Test conditions	MIN	MAX	UNIT
Collector-base breakdown voltage	$V_{(BR)CBO}$	$I_C=-100\mu\text{A}, I_E=0$	-40		V
Collector-emitter breakdown voltage	$V_{(BR)CEO}$	$I_C=-0.1\text{mA}, I_B=0$	-25		V
Emitter-base breakdown voltage	$V_{(BR)EBO}$	$I_E=-100\mu\text{A}, I_C=0$	-5		V
Collector cut-off current	I_{CBO}	$V_{CB}=-40\text{V}, I_E=0$		-0.1	μA
Collector cut-off current	I_{CEO}	$V_{CE}=-20\text{V}, I_B=0$		-0.1	μA
Emitter cut-off current	I_{EBO}	$V_{EB}=-5\text{V}, I_C=0$		-0.1	μA
DC current gain	$h_{FE(1)}$	$V_{CE}=-1\text{V}, I_C=-100\text{mA}$	120	400	
	$h_{FE(2)}$	$V_{CE}=-1\text{V}, I_C=-800\text{mA}$	40		
Collector-emitter saturation voltage	$V_{CE(sat)}$	$I_C=-800\text{mA}, I_B=-80\text{mA}$		-0.5	V
Base-emitter saturation voltage	$V_{BE(sat)}$	$I_C=-800\text{mA}, I_B=-80\text{mA}$		-1.2	V
Base-emitter on voltage	$V_{BE(on)}$	$I_C=-1\text{V}, V_{CE}=-10\text{mA}$		-1	V
Base-emitter positive favor voltage	V_{BEF}	$I_B=-1\text{A}$		-1.55	V
Transition frequency	f_T	$V_{CE}=-10\text{V}, I_C=-50\text{mA}$ $f=30\text{MHz}$	100		MHz
output capacitance	C_{ob}	$(V_{CB}=-10\text{V}, I_E=0, f=1\text{MHz})$		20	pF

CLASSIFICATION OF $h_{FE(1)}$

RANK	L	H	J
RANGE	120 - 200	200 - 350	300 - 400



CHINA BASE
INTERNATIONAL

SOT-323

SS8550W



www.china-base.com.hk

Typical Characteristics

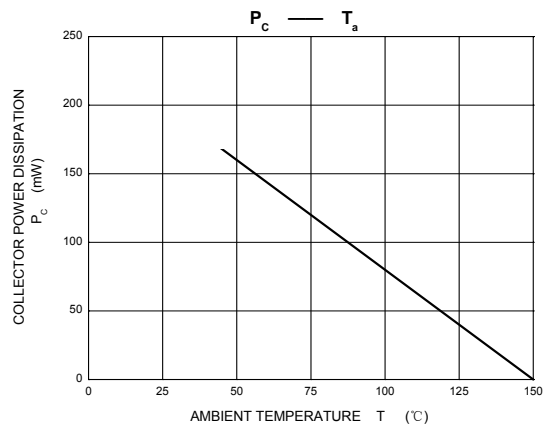
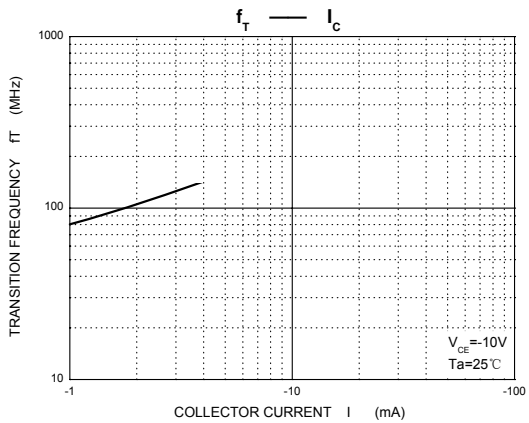
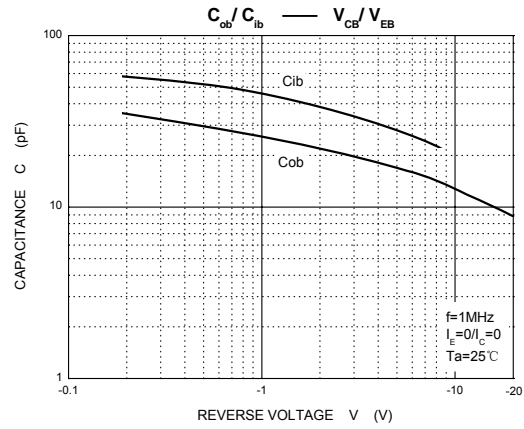
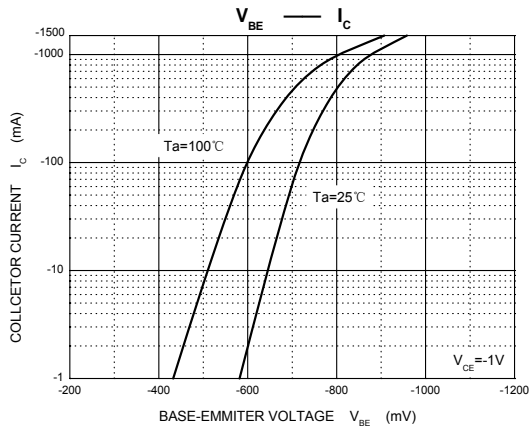
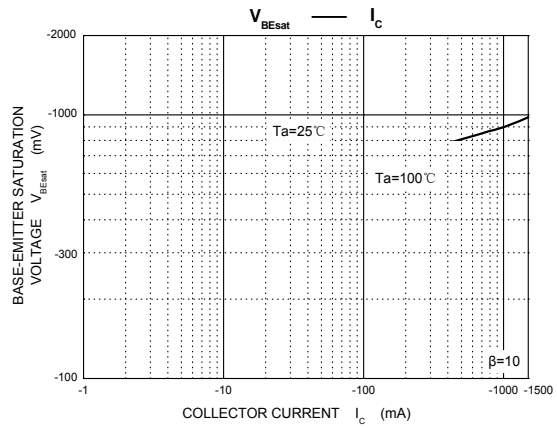
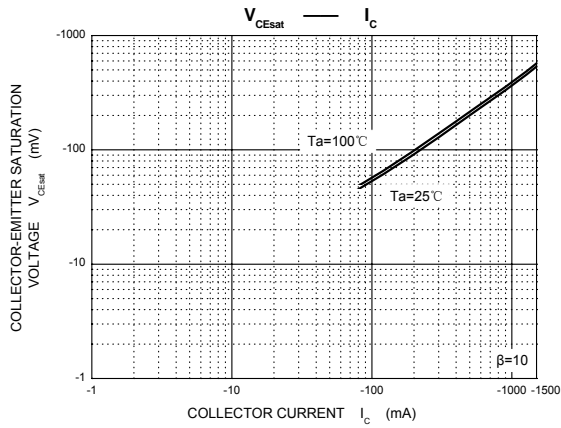
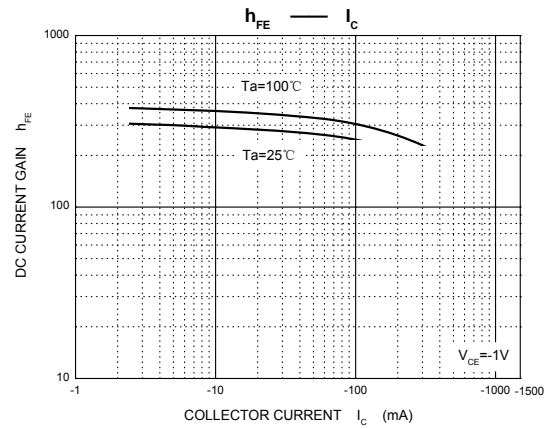
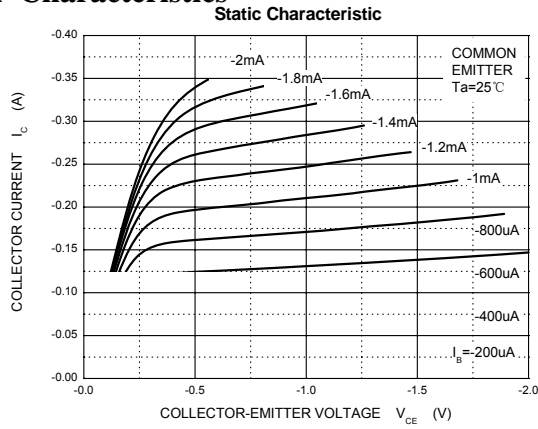



SOT-323 Package Outline Dimensions

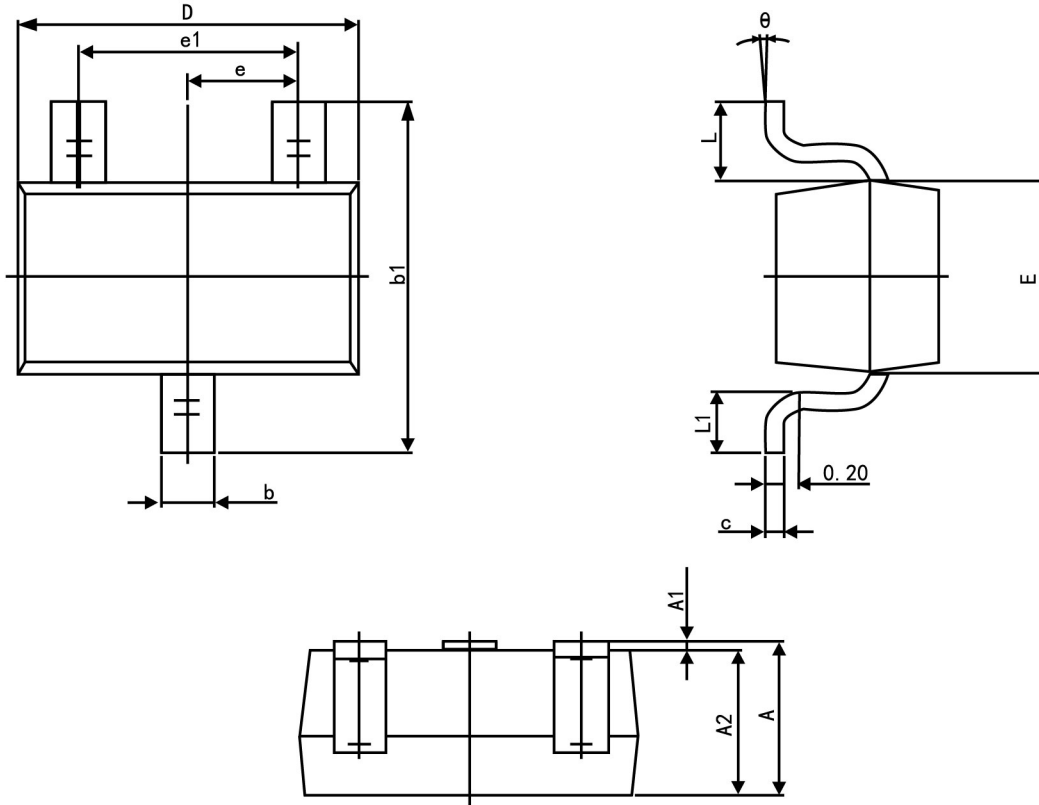

Symbol	Dimension in Millimeters	
	Min	Max
A	0.900	1.100
A1	0.000	0.100
A2	0.900	1.000
b	0.200	0.400
c	0.080	0.150
D	2.000	2.200
E	1.150	1.350
E1	2.150	2.450
e	0.650 TYP.	
e1	1.200	1.400
L	0.525 REF.	
L1	0.260	0.460
theta	0°	8°